



GEORGIA

DEPARTMENT OF NATURAL RESOURCES

WILDLIFE RESOURCES DIVISION

GUIDE TO ALLIGATOR HUNTING IN GEORGIA

INTRODUCTION

Hunters interested in participating in a hunting adventure unlike any other are invited to apply online at www.gohuntgeorgia.com and take part in the alligator hunting season. Other aspects of the state's alligator management program include a nuisance alligator agent trap-per program, harvest surveys and scientific population monitoring activities.

Prior to the alligator hunting season, hunters are selected through an online quota application system and random selection process. Each selected hunter may harvest one alligator (of at least 48 inches in length) from a specified zone and using specific methods.

History of the alligator hunting season: In the fall of 2001, WRD personnel developed a conceptual framework for an alligator hunting season. Regulatory proposals included capture techniques, dispatch methods, hunt locations and seasons. The first alligator hunting season was held in September 2003. This first season was a success and paved the way for future seasons.

WRD believes the alligator hunting season is integral to the continued conservation of the American alligator in Georgia, adds to the value of alligators, and allows citizens to benefit from this sustainable and renewable natural resource.

ALLIGATOR INFORMATION

HISTORY

The American Alligator (*Alligator mississippiensis*) has changed little from its original form some 180 million years ago. Alligators were hunted to near extinction in the 1950's and early 1960's, but protective action by state and federal governments helped keep them from disappearing completely.

This type of protection allowed the alligator population to increase. They were removed from "total protection" status in 1987. The alligator now has a status of "threatened due to similarity of appearance" because of its likeness to other crocodylians worldwide that still receive protection. The removal from total protection status allows Georgia and other south-eastern states greater flexibility in managing alligator populations.

POPULATION

There are approximately 200,000-250,000 alligators in the state of Georgia.

RANGE

Alligators occur from the southern tip of Texas to the northeastern part of North Carolina. In Georgia, they typically live along and south of the fall line (which roughly traverses the cities of Columbus, Macon and Augusta). There is no evidence that alligator populations reproduce north of the fall line and any found in these areas have probably been relocated there by humans. Alligators usually remain in the area where they were born for two to three years and then begin looking for their own range. Females generally have small home ranges while a male may occupy a range of more than two square miles. Severe drought conditions may cause alligators to move considerable distances in search of suitable waters.

HABITAT

Alligators occupy a variety of wetland habitats in Georgia. They are found in marshes, swamps, rivers, farm ponds and lakes in the wild, but also have been found in ditches, neighborhoods, drainage canals, roadways, golf course ponds and sometimes in swimming pools. During the courtship and breeding season, April to May, alligators prefer open waters. During the remainder of the year, males prefer open and deep waters while females seek out nesting habitat in shallow, heavily vegetated and secluded areas.

TRAITS

Alligators can live up to 60 years in captivity but in the wild they rarely live more than 50 years. Male alligators can grow up to 16 feet in length, although 14 footers are rare, and female alligators can grow up to 10 feet. After breeding, females lay an average of 35 to 40 eggs that incubate for about 65 days. Alligators are about eight to ten inches in length when born. About 20 percent of the young will survive to maturity, the others fall victim to predators such as raccoons, birds, snakes, otters and other alligators. They grow approximately eight to ten inches per year for the first few years and will reach sexual maturity when they reach about six feet in length. Large alligators can reach weights of over 800 pounds. Alligators are carnivores and will eat almost anything they can catch. During the first few years their diet consists mainly of small prey such as snails, crayfish, frogs, insects and other invertebrates. Depending on their size, larger gators may eat fish, turtles, snakes, waterfowl, raccoons, beavers and otters. Alligators also feed on carrion and given the opportunity they also may eat pets and smaller domestic animals, such as goats and pigs.

NUISANCE

In 1989, the Georgia DNR initiated a nuisance alligator program that allows licensed agent trappers to capture and harvest specific nuisance alligators four feet or larger. A nuisance alligator is one that (1) is located outside of its normal range, (2) has been fed, intentionally or not, by humans, or (3) become so habituated to humans that they no longer move away from humans or become aggressive.

ALLIGATOR/HUMAN INCIDENTS

From 1980-May 2007, there only have been nine reported cases of alligator attacks on humans in Georgia, including one fatality in 2007. Six of these incidents happened as a result of the human stepping on or otherwise making contact with a submerged alligator. The remaining three incidents were a result of the alligator mistaking the human for prey.

BENEFITS

Alligators are important in nature. They help maintain the population balance of certain prey species and they help shape and modify habitats. During times of severe drought, alligators are known to dig holes (gator holes) to concentrate water. This helps the alligator survive, and helps many other species of plants and animals in the area.

HUNT APPLICATION PROCESS

Georgia's alligator hunting season has been designated as a quota hunt where a limited number of hunters are allowed to harvest one alligator (of 48 inches or greater length) each from a specified hunt zone. This allows the Department to closely monitor the number of animals harvested.

Hunters must apply electronically (www.GoOutdoorsGeorgia.com) by 11:59 p.m. on July 15. When applying, hunters select (in order of preference) preferred hunt zones. Hunt zones and the number of quota permits available for each zone is available on the WRD website (www.georgiawildlife.com/hunting/alligator). Make sure that your email is current and correct in order to receive quota updates, confirmations or any notices about quota hunts.

A random computer drawing selects the applicants for each hunt zone. Each selected applicant may hunt only the zone for which they were chosen and may harvest only one alligator.

No person under 12 years of age may apply for an alligator hunting permit or accompany a permitted alligator hunter during a hunt. The selected hunter may have as many assistants or helpers as desired. The permittee or his assistants may hunt and take alligators as provided in the harvest permit, but only in the presence of the permittee.

Selected hunters will receive an alligator harvest permit and temporary alligator harvest tag by mail. Permits and tags are not transferable and must be in possession while hunting.

Hunters not selected for a hunt will have their quota hunt account credited with a priority point. Priority points may be used with future applications to receive priority status in the selection process.

***Deadline to Apply for an Alligator
Quota Hunt is July 15***

PREPARING FOR THE HUNT

LICENSE REQUIREMENTS

The permitted alligator hunter must possess a hunting license, in addition to a quota alligator harvest permit (\$75). Lifetime and honorary license holders are exempt from these requirements. Persons accompanying a permitted alligator hunter and actively participating in the hunt (e.g., operating the boat, holding a spotlight or otherwise assisting in the search, capture or dispatch of an alligator) must have a current hunting license. Possession of a valid license is not required to apply for quota hunts.

PRE-HUNT TIPS

- Purchase your hunting equipment and become familiar with it in advance.
- Obtain maps of the zone you will hunt and familiarize yourself with the area.
- Determine who will accompany you for the hunt (e.g., select a guide if desired) and ensure that everyone has appropriate licenses. Determine who will handle each responsibility during the course of the hunt (e.g., drive the boat, snare, dispatch, etc.).
- If you plan to hunt on private property, you must obtain written permission from the land owner to be on the property and have it in your possession while hunting.
- Develop a plan on how you are going to cool the alligator as quickly as possible once it is harvested.
- Keep your hunting permit and tag in a safe place. Replacements will not be issued.

CHECKLIST: WHAT YOU NEED

- Quota alligator harvest permit, hunting license, approval permit, and temporary alligator harvest tag.
- Written permission from landowner if hunting on private land.
- Boat and required equipment such as functioning running lights and life jackets. Please note that WRD encourages all hunters to wear a life jacket while participating).
- Lighting equipment. A light may be used.
- Preferred capture equipment: snare, gig, harpoon or arrow.
- Restraint equipment: snare for neck and snare for snout.
- Preferred dispatch equipment: handgun or bangstick.
- Knife to cut into alligator's tail to insert the temporary alligator harvest tag.
- Preferred cooling method.
- Processing plans.

SAFETY NOTICE

There are several effective techniques available for capturing and harvesting alligators. Keep in mind that while these techniques have proven effective in alligator harvests, there is an element of danger involved with the process. The techniques, equipment and practices described are provided only to demonstrate practical techniques that agent alligator trappers have used in conjunction with the nuisance alligator program. Please use extreme caution when handling alligators.

ALLIGATOR CAPTURE AND HARVEST TECHNIQUES

All effective alligator hunting techniques have a few common elements.

- Alligators are invariably hunted after dark (although some hunters use snatch-hooks on animals during twilight hours). A light may be used.
- Alligators are located at night by their reflective eye-shine, which is a characteristic red glow.
- Alligators should be approached quietly keeping the beam of the spotlight directly in or just above their eyes.

CAPTURE METHODS

Alligators must be captured alive prior to shooting or otherwise dispatching the animal. It is unlawful to kill an unrestrained alligator. In order to capture an alligator, the hunter must first secure a restraining line to the animal. Several methods may be used to attach a restraining line to an alligator, including hand-held snares, harpoons, gigs, arrows or snatch hooks. It is up to the individual hunter to decide which method will work best.

Once the restraining line is attached, the alligator should be retrieved with moderate pressure applied to the line. It is important to note that pulling too hard on the restraining line will often cause it to pull loose. A snare should be cautiously attached to the alligator once it is adjacent to the boat. It is best to use a snare that has been attached to a pole with either a rubber band or a piece of tape so that it will "break-away" upon pulling the snare secure around the animal's neck. Alligators typically thrash and roll when the snare is applied, but should calm down after they tire.

DISPATCH METHODS

Once the alligator has been captured and brought adjacent to the boat it shall be dispatched. The animal may be killed with the use of a bangstick or any caliber handgun. To use a bangstick, the hunter should first allow the alligator's head to go below the water's surface. The hunter should then discharge the bangstick at the base of the skull. The animal also may be dispatched by discharging a handgun at the base of the skull. Both the bangstick and the handgun should be aimed at the brain, angled slightly forward from the rear of the skull. Hunters should note that the improper placement and discharge of the handgun or bangstick can occasionally only knock the alligator temporarily unconscious.

**NEVER ASSUME THAT ANY
ALLIGATOR IS DEAD**

NOTE: No firearm, except a bangstick or handgun, may be in possession while hunting alligators.

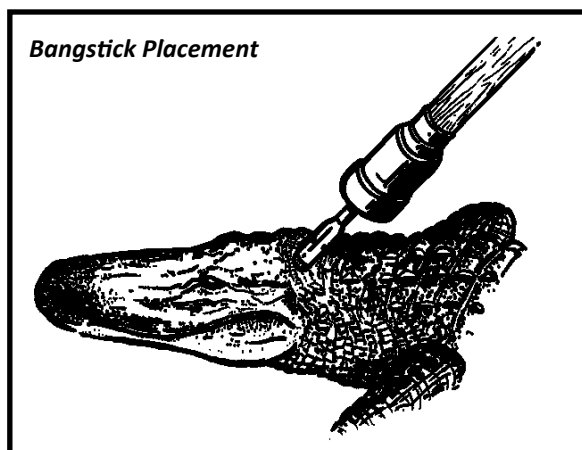

Using the snare, carefully pull the alligator's snout up against the side of the boat (to the edge of the gunnel) and press the top of the snout closed with a stick to secure. Never place your hand or foot next to an alligator's jaw because they can snap sideways very quickly and cause serious injury. A rope (tossed or guided by a stick rather than your hand) can be used to temporarily secure the jaw. Once this temporary method is applied, the jaw should then be completely secured by wrapping it several times with high quality duct-tape or electrical tape. As a final measure, the spinal cord should be severed at the base of the skull before placing the alligator in the bottom of the boat. Remember, jaws should remain taped shut when handling or transporting an "apparently" dead alligator.

Estimating Alligator Length

The length of an alligator can be estimated by determining (in inches) the distance between the center of the skull (between the eyes) and the nostrils. This number then can be translated into feet to give an estimate of the entire length of the animal. For example, if the measurement on the top diagram was eight inches, One can estimate that the entire animal is approximately eight feet long.

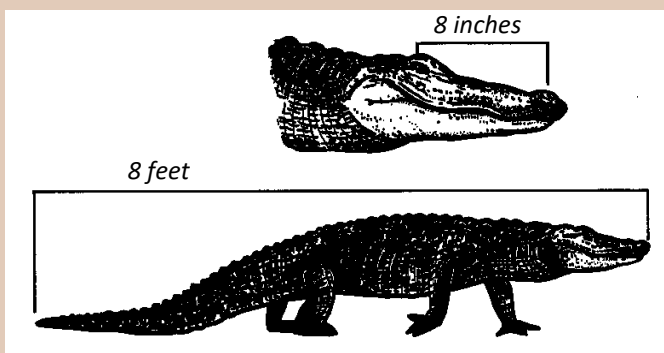

CAPTURE AND DISPATCH TOOLS

Snares: Wire snares attached to a restraining line that is loosely mounted (using a small rubber band or piece of tape) to the end of a pole are most commonly used to secure the alligator once it has been harpooned or snagged and brought under control near the boat. Snares also may be used as an initial capture technique. Snares must be hand-held or attached to a hand-held device and cannot be left unattended.

Harpoons and Gigs: Harpoons or gigs may be used for attaching a restraining line to an alligator. Harpoons or gigs consist of a penetrating point such as a straightened fish hook, detachable dart, fish gig or spear point that is attached to a restraining line. The harpoon point is typically mounted on a pole, arrow shaft or spear and is thrown. A gig (a pronged instrument with a metal or wooden pole) is jabbed.

Diagram of a commonly used harpoon point

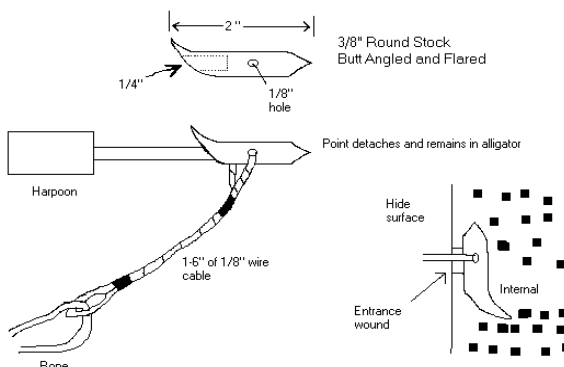

Snatch Hooks: Snatch hooks may be used for attaching a restraining line to an alligator. A snatch hook is a weighted treble hook that is attached to a restraining line. The hook is either hand-held or used in conjunction with a long, stout fishing rod and reel and heavy line. The hook typically is cast over the alligator or over the area where it last submerged. The hook is then retrieved until it makes contact with the alligator, at which point it is set with a strong pull. The line should be kept tight until the animal tires, as the hook often falls out of the alligator if the line is allowed to go slack. **Baited hooks are not a legal capture method.**

Handgun: Any caliber handgun may be used to dispatch a captured alligator. Rifles are not allowed to be used as a dispatch tool and may not be in possession while hunting alligators. Alligators may not be shot until captured and restrained.

Bangsticks: Bangsticks are a safe and effective tool for humanely killing alligators. Bangsticks or power heads, typically used by divers to kill fish, discharge a firearm cartridge upon contact. For a humane kill, the shot should be centered immediately behind the skull cap and angled toward the brain. It is recommended that the bangstick be used in compliance with the manufacturer's safety recommendations. When killing an alligator, the bangstick should be discharged below the waterline to reduce the potential for aerial dispersal of bullet and bone fragments. Keep in mind that to legally dispatch an alligator using a bangstick, the animal must be attached to a restraining line using methods such as those previously described.



WARNING

A bangstick is a firearm under the laws of Georgia, and should be treated at all times with the respect due such a device. While these materials are offered to familiarize participants with the appropriate and safe use of a bangstick, WRD cannot warrant that such use will be safe under all circumstances, nor is this brief introduction intended as a substitute for the degree of experience and knowledge necessary to safely utilize such a device. In the event you choose to utilize a bangstick to harvest alligators, you should select a model, which the manufacturer deems appropriate for such use, and should, at all times, comply with manufacturer's safety recommendations and specifications for use.

AVAILABILITY OF CAPTURE AND DISPATCH TOOLS

Bangsticks and/or gigs:

- Central Florida Trophy Hunts; 321-632-8995; centralfloridatrophyhunts.com
- Scuba Shack, Waycross, GA; (912) 283-6444
- Bud's Bangsticks, FL; (772) 468-7711; bangsticks.com
- Beco Products; 1-800-720-1905; beco-products.com
- Gator Guides; 813-968-6154; gatorguides.com/ratworks.htm

Snares:

- Jerry Lee, Alma, GA; (912) 632-0473 or (912) 337-5522
- R-P Outdoors, LA; 1-800-762-2706; rpoutdoors.com
- The Snare Shop, IA; (712) 792-0600; snareshop.com

Note: Alligator hunting equipment also may be available from your local outdoor sporting goods store or from other on-line vendors.

Disclaimer: The above vendor listing is provided to allow convenient access to equipment sought by those interested in alligator hunting. WRD neither endorses these companies or receives any compensation for placing these names in this booklet. Equipment purchased through these companies is done so at the buyers own risk and of their own will.

WHAT TO DO AFTER YOUR ALLIGATOR IS HARVESTED

After the alligator is harvested, you must be prepared to do the following:

- Attach the harvest tag to the alligator's tail.
- Complete the harvest permit within 24 hours of taking the animal.
- Cool the harvested alligator.
- Take alligator carcass or hide to a WRD Game Management Office for validation.

ATTACHING THE TEMPORARY HARVEST TAG

You must attach the temporary alligator harvest tag to the alligator carcass within six (6) inches of the tip of the tail (see diagram to the right). The harvest tag must remain attached to the alligator hide at all times until validation of the hide by a WRD Game Management Office. Please note, it is difficult to cut through an alligator's hide, so take your time and be careful not to cut yourself. Also, be sure to clamp your harvest tag across the underside of the tail to avoid jeopardizing the ability to skin the hide.

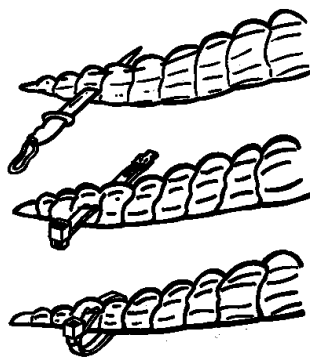

COMPLETING THE HARVEST PERMIT

The alligator harvest permit must be completed within 24 hours of harvesting the alligator. A copy of the alligator harvest permit must accompany the alligator hide at all times until validation by a WRD Game Management Office. Please be sure to read and follow the directions carefully and fill the permit out completely.

COOLING THE HARVESTED ALLIGATOR

To maintain meat and hide quality, take necessary steps to cool your harvested alligator to 45 degrees Fahrenheit within four (4) hours after harvest.

VALIDATING THE HIDE

All alligator carcasses or hides shall be taken during normal working hours (M-F, 8 a.m. - 4:30 p.m.) to a WRD Game Management Office (locations and phone numbers at www.georgiawildlife.com/about/contact), or other designated location, for CITES validation no later than October 15. The temporary harvest tag must remain locked onto the alligator's tail until validation. CITES tags issued by WRD must remain attached to the hide until it is tanned, taxidermy mounted or exported from the state. **The possession of any alligator hide not tagged (with either a temporary tag or a validated tag) is prohibited.**

SKINNING, PROCESSING, CURING AND TANNING

SKINNING

Skinning an alligator is a delicate process if the hunter wishes to retain the beauty of the hide. Patience and special care must be taken to prevent accidental knife cuts in the hide.

Note: Scutes or osteoderms are the bony plates embedded in the back skin of an alligator. They give the alligator the bumpy appearance and protect the alligator.

Alligators may be skinned in two different ways:

Method 1

This method leaves the belly skin of the alligator intact and is the preferred method if the hide is to be sold or tanned and made into leather goods. This method consists of making an incision on each side of the alligator (leaving one to two rows of osteoderms or scutes along the belly side) and on the top of each leg and then removing the hide with the belly skin intact. The underside of the skull also should be skinned with the rest of the belly. The back skin of the alligator with the osteoderms or scutes in it can then be removed and discarded or kept according to your wishes. Because of the difficulty of tanning the osteoderms, the back skin is not considered very useful and most often is discarded.

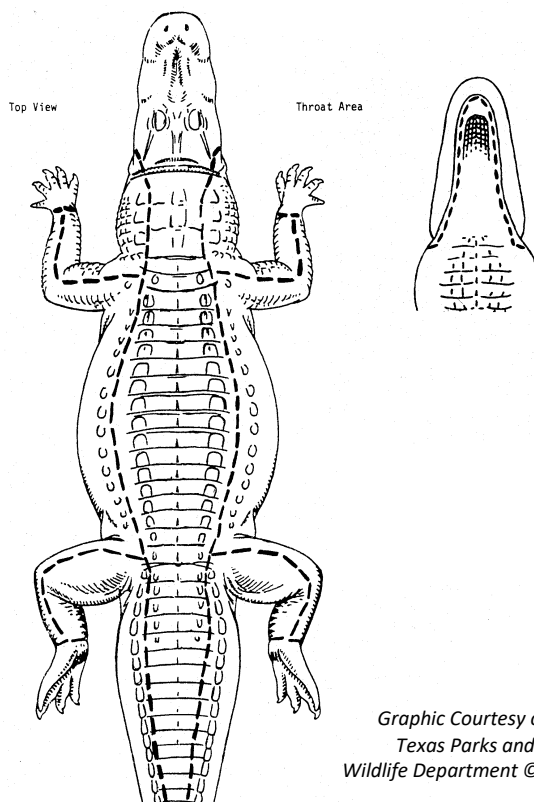

Graphic Courtesy of:
Texas Parks and
Wildlife Department © 2002

Method 2

This method produces a more natural looking hide but generally is more costly to tan due to the osteoderms remaining in the hide. This method is similar to skinning a deer or a hog by making an incision up the belly of the alligator and on the underside of each leg. The hide can then be removed in its entirety and saved for tanning or selling.

Note: *Alligator skulls and skeletal parts not discarded must be permanently marked with the alligator harvest tag number of the hide from which it was taken. This marking may be written on the palate of the mouth after preservation. The skull and skeletal parts may be kept by the selected hunter, transferred or sold. Records must be kept indicating to whom skulls and/or other skeletal parts were transferred.*

PROCESSING

Alligator meat may be processed and stored in a fashion similar to that for deer, hog and other game animals. While the tail meat is the most popular consumable meat of alligators, it is not the only edible portion. Many people find the ribs, legs, etc. good.

Note: *Only alligator meat that is commercially processed at an approved facility may be sold commercially. Approved facilities are those licensed as seafood processors by the Georgia Department of Agriculture.*

Recommended Consumption Guidance for Wild Alligator

In conjunction with the limited harvest of alligators allowed this year, the Georgia Department of Natural Resources (GA DNR) is issuing recommendations on the consumption of wild alligator meat. Alligators are long-lived, may grow to large sizes, and may accumulate significant amounts of mercury. Information on mercury in alligators harvested in Georgia is limited, but suggests that certain people may be at risk if consumption of alligator meat occurs.

GA DNR has carefully reviewed this information, and recommends that the general population eat no more than 1 meal per week (8 ounces or ½ pound) of alligator meat. Pregnant women, nursing mothers, and young children may be especially sensitive to the effects of mercury. For this potentially sensitive population, GA DNR recommends that no more than 1 meal per month be consumed.

This recommendation may be particularly important if you are a frequent consumer of locally caught fish, which also may contain mercury. For further information contact a WRD Game Management Office (info listed at end of booklet) or the Georgia Environmental Protection Division at (706) 369-6376.

PROCESSORS

Alligator processors must be licensed seafood processors. A list of processors is available at www.georgiawildlife.com/hunting/processors.

TAXIDERMISTRY AND TANNING

If you wish to have the alligator mounted, contact one of the many commercial taxidermists in the state for assistance. If you wish to tan the alligator hide, contact American Tanning and Leather Co. in Griffin, Georgia (amtan.com or 770-228-4433) or John Walker Taxidermy (johnwalkergators.com or 352-669-6446).

CURING

Two methods may be used to temporarily preserve and/or cure alligator skin until sold or sent to a tannery. Method one is through repeated salting of the hide and storing it in a cool, dry location. Method two (which utilizes some similar techniques to method one) is through the use of a brine solution.

Method One

After an alligator has been skinned, the hide should be scraped thoroughly using a knife, a piece of metal pipe or another appropriate object until all bits of meat, fat, etc. are removed. After scraping, salt the hide with approximately one inch of white, fine grade table or mixing salt (available at most feed and seed stores). Thoroughly rub the salt into the hide, then roll the hide tightly, secure it and store it in a cool place. After 3-5 days, unroll the hide, discard the salt and repeat the salting procedure as described above. Re-roll the hide tightly and band with a one-inch rubber band or other rubber tubing. Store the rolled hide in a cool, dry place until transported for validation.

Method Two

An alternative to Method One is to utilize a brine solution. Hides cured in brine solutions often remain more supple, suffer less shrinkage and are viewed as more attractive by hide graders and buyers. For these reasons, the use of a brine solution to cure an alligator hide is highly recommended.

Ingredients or Materials Needed:

- 50 gallon covered plastic drum
- 50 pounds salt
- 1 pint bleach (assists in keeping bacterial growth to a minimum)
- 25 gallons water

In order to be effective, the solution must be carefully prepared and maintained. A plastic or other non-corrosive covered container of sufficient size should be used. Heavy, 50-gallon plastic drums used for shipping produce are best but large plastic covered garbage cans are good substitutes. The solution must remain saturated with salt. Too little salt will cause damage to a hide.

Fill the 50-gallon container half-full of water, then add the salt and the bleach and mix thoroughly. After complete mixing, a 2-3 inch layer of salt should remain on the bottom. Hides should be properly scraped and salted with a one-inch layer of salt, tightly rolled and secured with a rubber band prior to placing in the brine. When submersing a hide in the brine, it should be rotated to allow most of the air pockets to escape. If properly salted, the layer of salt in the rolled skin will act as a wick to draw the brine solution throughout the skin. The hide should be entirely submersed in the brine at all times and the container should be kept tightly covered to keep insects and airborne contaminants from entering the solution.

The hide should remain in the brine solution until sold or sent to a tannery. If you plan on selling the hide, it must be removed from the brine and entirely re-salted prior to being shipped or placed in refrigeration. The brine should be discarded and a new solution made after each use. Disposal of the salt brine should be done properly and carefully since it is harmful to plants and aquatic animal life.

WRD GAME MANAGEMENT OFFICES

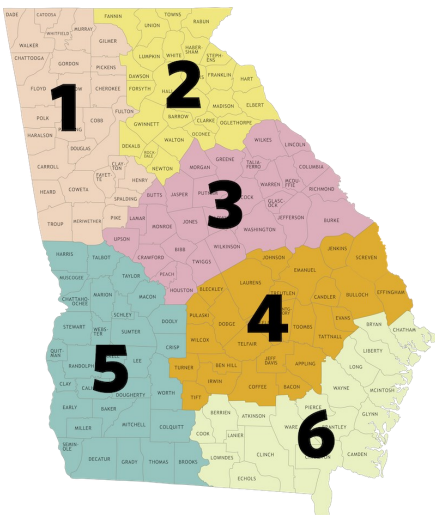

Region 1

2592 Floyd Springs Rd.
Armuchee, GA 30105
706-295-6041

Region 2

2150 Dawsonville Hwy.
Gainesville, GA 30501
770-535-5700

Region 3

142 Bob Kirk Rd.
Thomson, GA 30824
706-595-4222

Region 4

1014 MLK, Jr. Blvd.
Fort Valley, GA 31030
478-825-6354

Region 5

2024 Newton Rd.
Albany, GA 31701
229-430-4254

Region 6

1773-A Bowen's Mill Hwy.
Fitzgerald, GA 31750
229-426-5267

Region 7

One Conservation Way
Brunswick, GA 31520
912-262-3173

Acknowledgements

Georgia DNR Authors:

Greg Waters, Sr. Wildlife Biologist, Game Management Section

John Bowers, Chief, Game Management Section

Melissa Cummings, Public Affairs Office

We express our appreciation to Alligator Committee members for their assistance in reviewing and editing this booklet. We also express our appreciation to biologists with the Florida Fish and Wildlife Conservation Commission for the use of information from their "Public Waters Alligator Harvest Training and Orientation Manual" in the preparation of this book. WRD thanks Texas Parks and Wildlife Department © 2002 for the use of the artwork on page 9.

WWW.GOHUNTGEORGIA.COM

Revised: July 2018