



DEPARTMENT OF NATURAL RESOURCES  
COASTAL RESOURCES DIVISION  
ONE CONSERVATION WAY • BRUNSWICK, GA 31520 • 912.264.7218  
COASTALGADNR.ORG

MARK WILLIAMS  
COMMISSIONER

DOUG HAYMANS  
DIRECTOR

NOV 25 2019

William J. Young, Vice President  
Morningstar Marinas Golden Isles, LLC  
725 Park Center Drive  
Matthews, North Carolina 28105

**RE: Letter of Permission (LOP) for Marina Facility Maintenance, 206 Marina Drive, CMAA #224, Frederica River, Glynn County, Georgia. (GPS: 31.16811°N/ -81.41534°W)**

Dear Mr. Young:

This Letter of Permission (LOP) is in response to your request dated October 2, 2019 for partial replacement of a marina. The project consists of replacing “A” dock, “A” dock landing, “T” dock, connector dock, and the dock shop in the existing footprint. Any piling replacement will occur within or immediately adjacent to the original structure and will remain in the current footprint of the mooring docks. Old pilings will be removed or cut off at the mud line. Similarly, decking will also remain in the current footprint and configuration.

The existing “A” dock consists of a 10.25ft. x 403.42ft. floating dock with finger piers extending to the left and right. The finger piers to the left are 5.79ft. x 56.58ft. and the finger piers to the right are 5.79ft. x 40.42ft. There is a total of 9 finger piers to the left and 9 finger piers to the right of the main dock. “A” dock landing consists of a main 20ft. x 33.58ft. float for a ramp landing and a 16.5ft. x 10.58ft. float with a fish cleaning station.

The existing “T” dock consists of a 14ft. x 467.83ft. floating dock on the right side connected to a 10.58ft. x 140.75ft. floating dock on the left. The 13.6ft. x 22.95ft. dock shop is located to the right of “A” dock and landward of “T” where these two docks intersect. The dock shop is located on top of a 19.6ft. x 59.75ft. platform. The existing connector dock consists of 162.12ft. x 10.25ft. floating dock.

The project will begin no sooner than fifteen (15) days from the receipt of this letter and be completed no later than six (6) months after the date of this letter.

The Department authorizes the maintenance of the marina facility in the current footprint as depicted in the attached description and drawings. No unauthorized equipment, materials, or debris may be placed in, disposed of, or stored in jurisdictional areas. All material removed must be disposed of at an appropriate upland disposal area. Any visible alterations in marsh

NOV 25, 2019

LOP – Morningstar Marinas Golden Isles, LLC  
Page 2 of 2

topography will be restored immediately using low-impact hand tools. Any damage to the marsh vegetation that has not recovered naturally during the next growing season will be repaired by a method acceptable to the Department.

This authorization does not relieve you from obtaining any other required federal, state, or local permits. Tidal water bottoms and marshlands of coastal Georgia are public trust lands controlled by the State, except for such lands where a validated Crown Grant or State Grant exists.

Please contact Sam LaBarba at (912) 264-7218 should you require more information.

Sincerely,



Jill Andrews  
Chief, Coastal Management Section

Enclosures: Description and Drawings

Cc: Glynn County Building Department  
LOP20190150

**October 2, 2019**

**GA DNR Coastal Resources Division**

**Attention: Sam**

Coastal Permit Coordinator

One Conservation Way

Brunswick, GA 31520

**RE: Request a Letter of Permission to Repair / Replace docks at Morningstar Marinas Golden Isles LLC.**

Mr. Noble:

Morningstar Marinas Golden Isles LLC, was impacted by Hermine, Matthew and Irma. In November of 2017 we requested and were granted a letter of permission to begin the rebuilding process of the marina. We separated this process in three phases. Phase one and two were completed by June of 2018 with all docks being replaced in their pre-storm footprint.

We requested a letter of permission to tackle the last phase of this process consisting of the A dock and the T dock. In our application we included drawings and dimensions of the existing marina to illustrate the areas of work. Two areas were not addressed in the LOP received 9/27/2019:

- The A Dock Landing
  - o The existing A dock landing consists of a floating dock section that serves as the landing for the gangway, houses a fish cleaning station and is the intersection of A dock (from the East), M Dock (from the South), A dock Landing (from the West), and the Connector dock (from the North). The main landing area is a section of floating dock 20.00ft. x 33.583ft. (from West to East). The floating dock section housing the fish cleaning section run south from the main landing and is 16.5ft. x 10.583ft. The floating dock housing the fish cleaning section creates a 11.0ft. x 16.5ft. slip between it and M Dock.
- Connector Dock (from A Dock Landing going north to Rack Dock).
  - o The existing Connector Dock consists of a floating dock 162.125ft. x 10.25ft. (where it meets A dock going North).

If you have any questions or require additional information, please contact me at your convenience.

Sincerely,

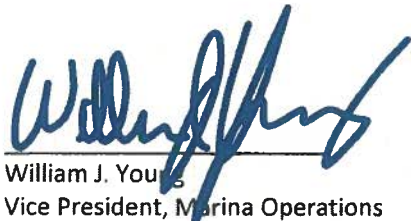

William J. Young  
Vice President, Marina Operations  
Morningstar Properties

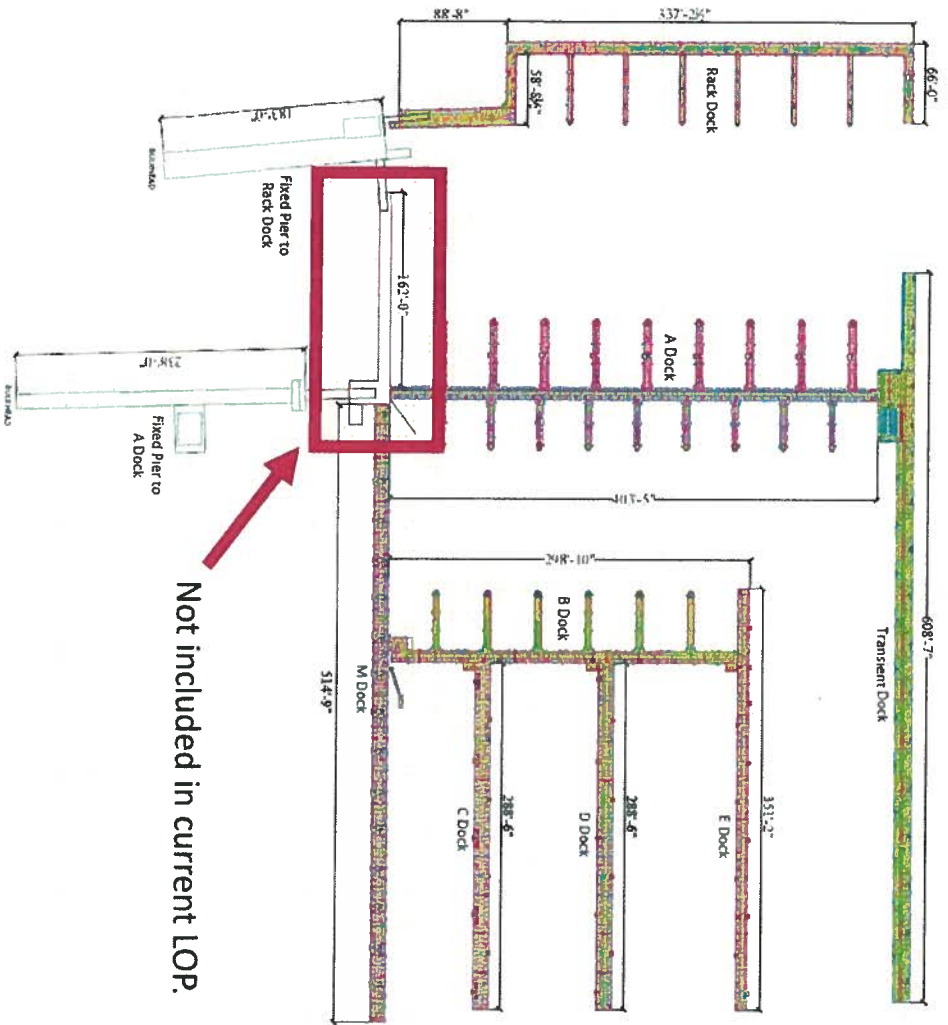

**wahoo DOCKS**

203 CHESTERINA DRIVE  
 DANHERM, CA 90533  
 PH: (770) 532-8411  
 FX: (770) 532-7983  
 www.wahoodocks.com

THE INFORMATION CONTAINED IN THIS DRAWING IS THE SCALE AND INTENTION OF THE DRAWING. ANY REVISIONS OR CORRECTIONS TO THIS DRAWING SHALL BE INDICATED BY A REVISION TABLE. THE WAAHOO DOCKS IS PROVIDING THIS INFORMATION AS A SERVICE WITHOUT ANY WARRANTY.

DOCK TYPE

CATS/XTREME

VIEW

FULL MARINA

DEALER	WAHOO COMMERCIAL
JOB NAME	GOLDEN ISLE - EXISTING

DATE  
 19SEP2019

DESIGNED BY  
 ERM

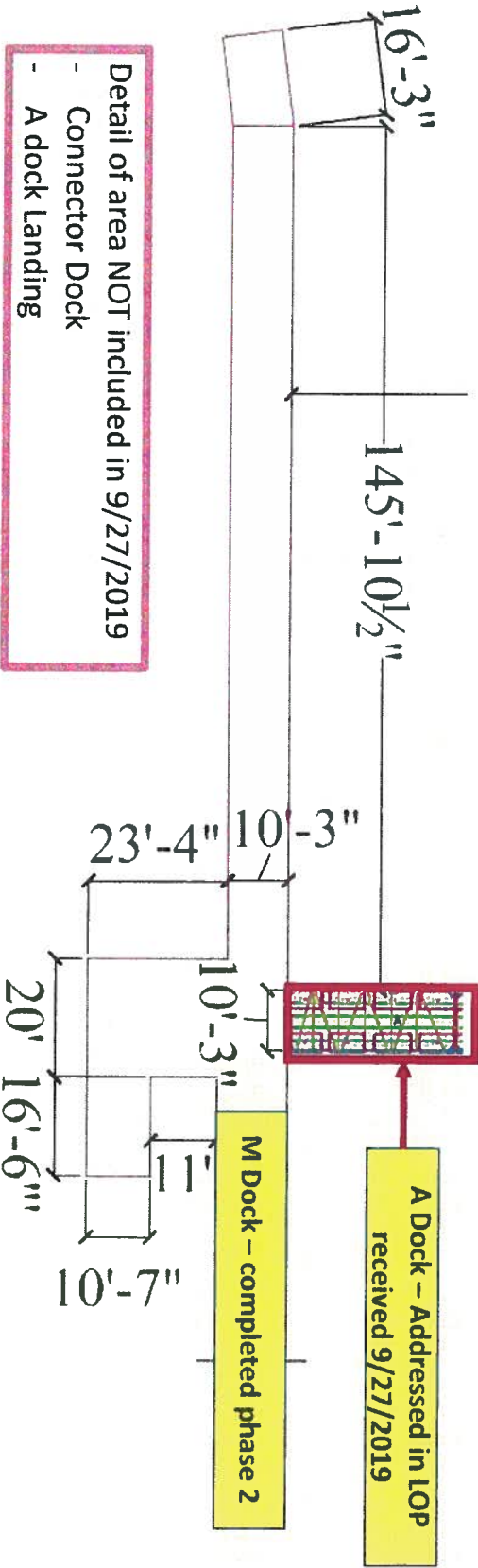

DESIGNED BY		ERM	
DATE		19SEP2019	
DEALER	WAHOO COMMERCIAL		
JOB NAME	GOLDEN ISLE - EXISTING		
VIEW	A & CONN. DOCK		
DOCK TYPE	CAT 5		
PROPERTY OF WAHOO DOCKS. ANY REPRODUCTION IN PART OR AS A WHOLE WITHOUT THE WRITTEN PERMISSION OF WAHOO DOCKS IS PROHIBITED.			











**LEGAL DESCRIPTIONS**

**NOTE:** The following is a summary of the property as shown in the plat and is not intended to be a legal description. A legal description of the property is shown on the plat and is the only one to be used for all purposes. The plat is a true and correct copy of the original as recorded in the office of the County Clerk, Harris County, Texas, on 11/28/12. The plat is a true and correct copy of the original as recorded in the office of the County Clerk, Harris County, Texas, on 11/28/12. The plat is a true and correct copy of the original as recorded in the office of the County Clerk, Harris County, Texas, on 11/28/12.

**TRACT 1**  
**LEGAL DESCRIPTION**  
 ALL THAT CERTAIN LOT, BEING ONE (1) OF TWO (2) LOTS, LOTS 1 AND 2, BEING IN BLOCK 10, LAMAR BLVD. SUBDIVISION, IN THE COUNTY OF HARRIS, TEXAS, AS SHOWN ON THE PLAT THEREOF, RECORDED IN THE PUBLIC RECORDS OF HARRIS COUNTY, TEXAS, IN BOOK 10, PAGE 10.

**TRACT 2**  
**LEGAL DESCRIPTION**  
 ALL THAT CERTAIN LOT, BEING ONE (1) OF TWO (2) LOTS, LOTS 1 AND 2, BEING IN BLOCK 10, LAMAR BLVD. SUBDIVISION, IN THE COUNTY OF HARRIS, TEXAS, AS SHOWN ON THE PLAT THEREOF, RECORDED IN THE PUBLIC RECORDS OF HARRIS COUNTY, TEXAS, IN BOOK 10, PAGE 10.

**TRACT 3**  
**LEGAL DESCRIPTION**  
 ALL THAT CERTAIN LOT, BEING ONE (1) OF TWO (2) LOTS, LOTS 1 AND 2, BEING IN BLOCK 10, LAMAR BLVD. SUBDIVISION, IN THE COUNTY OF HARRIS, TEXAS, AS SHOWN ON THE PLAT THEREOF, RECORDED IN THE PUBLIC RECORDS OF HARRIS COUNTY, TEXAS, IN BOOK 10, PAGE 10.

**TRACT 4**  
**LEGAL DESCRIPTION**  
 ALL THAT CERTAIN LOT, BEING ONE (1) OF TWO (2) LOTS, LOTS 1 AND 2, BEING IN BLOCK 10, LAMAR BLVD. SUBDIVISION, IN THE COUNTY OF HARRIS, TEXAS, AS SHOWN ON THE PLAT THEREOF, RECORDED IN THE PUBLIC RECORDS OF HARRIS COUNTY, TEXAS, IN BOOK 10, PAGE 10.

**SHEET 4 OF 4**

  
 GEORGE S. WILLIAMS, P.E.  
 12345 G. STREET, HOUSTON, TEXAS 77001  
 DATE: 11/28/12    SCALE: 1/4" = 1'    JOB # 12345  
 GEORGE S. WILLIAMS CONSULTANTS, P.A.C.  
 12345 G. STREET, HOUSTON, TEXAS 77001  
 PHONE: 713-123-4567

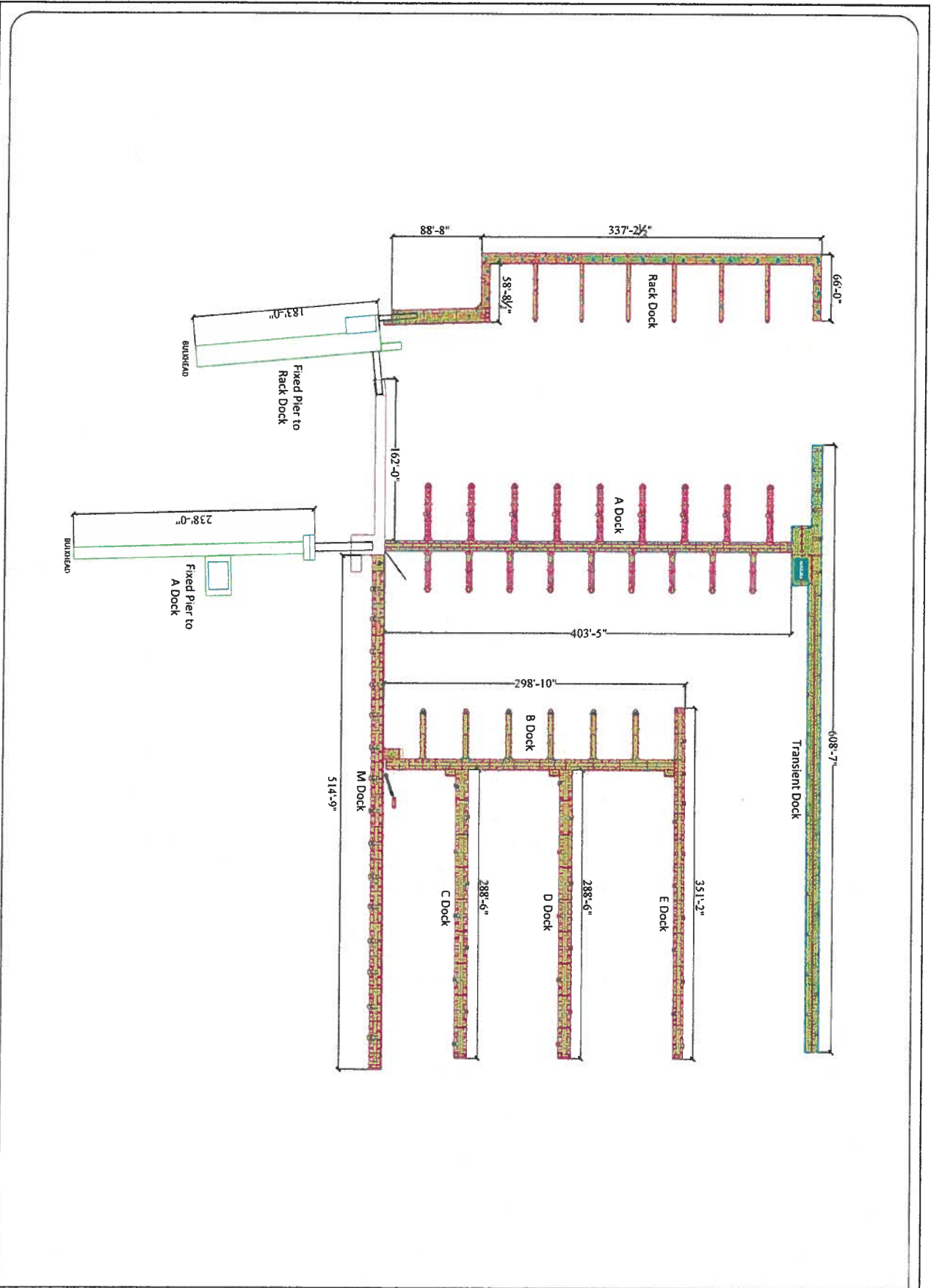

**wahoo**  
**Docks**

203 CHESTERRA DRIVE  
DAHLONEGA, GA 30533  
PH: (770) 532-8411  
FX: (770) 532-2983  
www.wahoodocks.com

THE INFORMATION CONTAINED IN THIS DRAWING IS THE SOLE PROPERTY OF WAHOO DOCKS. IT IS TO BE USED ONLY FOR THE PROJECT AND LOCATION SPECIFICALLY IDENTIFIED HEREIN. ANY REUSE OR MODIFICATION OF THIS DRAWING WITHOUT THE WRITTEN PERMISSION OF WAHOO DOCKS IS PROHIBITED.

DOCK TYPE

CATS/XTREME

VIEW

FULL MARINA

DEALER	WAHOO COMMERCIAL
JOB NAME	GOLDEN ISLE - EXISTING

DATE	19SEP2019
DESIGNED BY	ERM

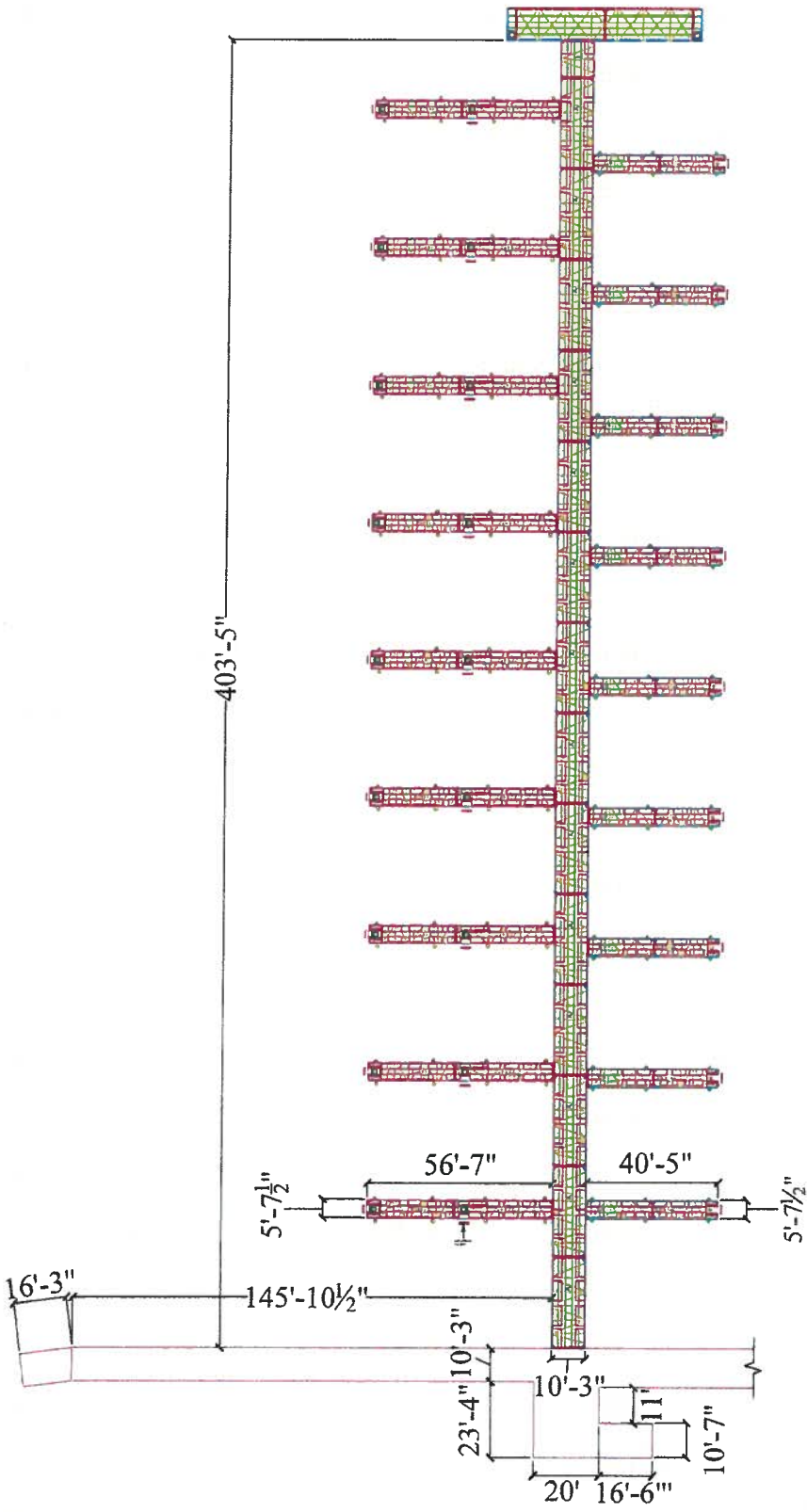

**wahoo DOCKS**

203 CHESTERRA DRIVE  
 DAHLONEGA, GA. 30533  
 PH: (770) 532-8411  
 FX: (770) 532-2883  
 www.wahoodocks.com

THE INFORMATION CONTAINED IN THIS DRAWING IS THE SOLE PROPERTY OF WAHOO DOCKS. ANY REPRODUCTION, STORAGE, OR USE AS A WHOLE WITHOUT THE WRITTEN PERMISSION OF WAHOO DOCKS IS PROHIBITED.

VIEW	A & CONN. DOCK
DOCK TYPE	CAT 5
DEALER	WAHOO COMMERCIAL
JOB NAME	GOLDEN ISLE - EXISTING
DATE	19SEP2019
DESIGNED BY	ERM



203 CHESTERRA DRIVE  
 DALLONCEA, GA 30533  
 PH: (770) 532-8411  
 FX: (770) 532-2983  
 www.wahoodocks.com

THE INFORMATION CONTAINED IN THIS DRAWING IS THE SOLE PROPERTY OF WAHOO DOCKS. ANY REPRODUCTION, IN ANY MANNER, WITHOUT THE WRITTEN PERMISSION OF WAHOO DOCKS IS PROHIBITED.

DOCK TYPE

XTREME

VIEW

TRANSIENT DOCK

DEALER	WAHOO COMMERCIAL
JOB NAME	GOLDEN ISLE - EXISTING

DATE	19SEP2019
DESIGNED BY	ERM

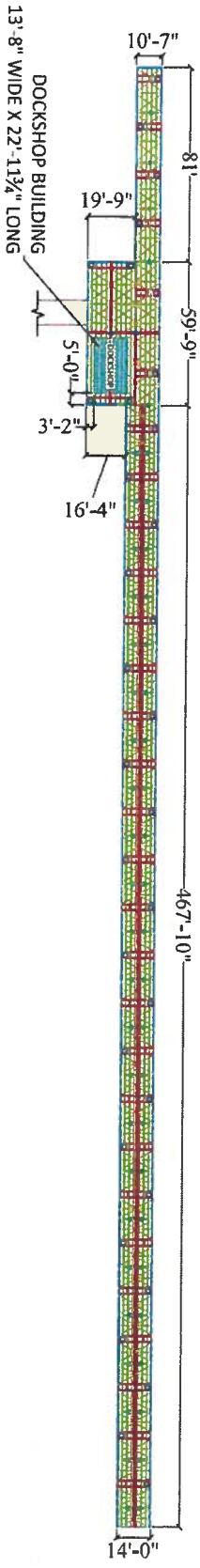

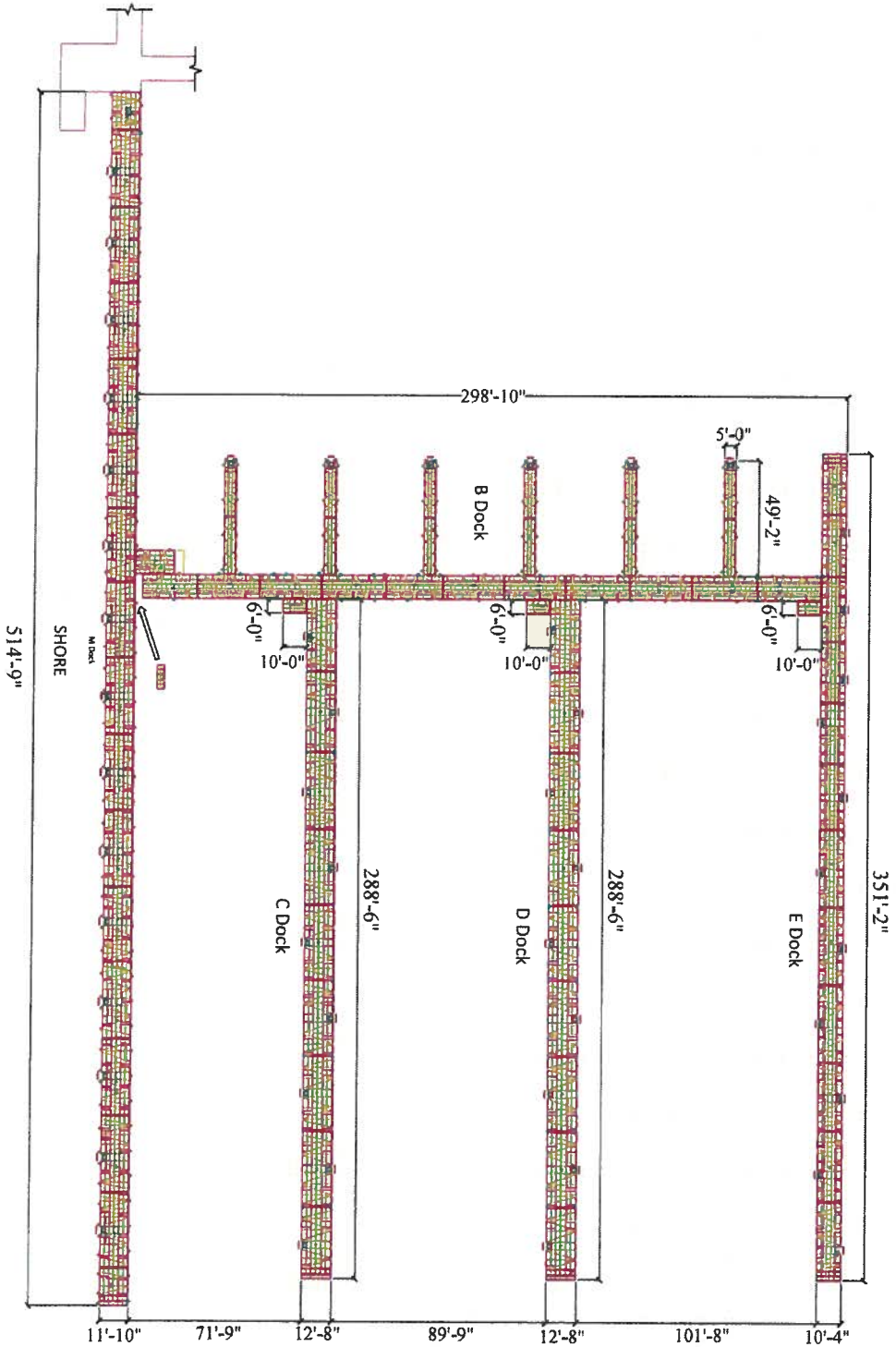

**Wahoo**  
DOCKS

203 CHESTERERA DRIVE  
DAHLONEGA, GA 30533  
PH: (770) 532-8411  
FX: (770) 532-2983  
www.wahoodocks.com

THE INFORMATION CONTAINED IN THIS DRAWING IS THE SOLE PROPERTY OF WAHOO DOCKS. NO PART OF THIS DRAWING OR AS A WHOLE WITHOUT THE WRITTEN PERMISSION OF WAHOO DOCKS IS FORWARDED.

DOCK TYPE

CATS/XTRME

VIEW

B,C,D,E,M DOCKS

DEALER  
WAHOO COMMERCIAL

JOB NAME  
GOLDEN ISLE - EXISTING

DATE  
19SEP2019

DESIGNED BY  
ERM



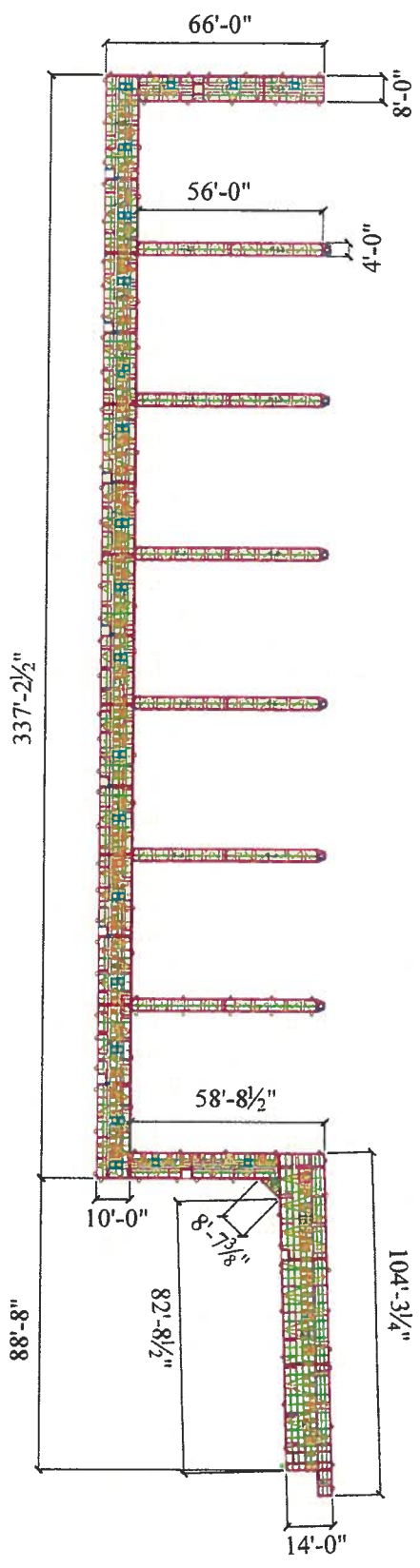

**wahoo DOCKS**  
 203 CHESTERFERRA DRIVE  
 DAHLONEGA, GA 30533  
 PH: (770) 532-8411  
 FX: (770) 532-2983  
 www.wahoodocks.com

THE INFORMATION CONTAINED IN THIS DRAWING IS THE SOLE PROPERTY OF WAHOO DOCKS. NO REPRODUCTION IN PART OR AS A WHOLE WITHOUT THE WRITTEN PERMISSION OF THE WAHOO DOCKS IS PROHIBITED.

DOCK TYPE  
 CAT 5

VIEW  
 RACK DOCK

DEALER	WAHOO COMMERCIAL
JOB NAME	GOLDEN ISLE - EXISTING

DATE  
 19SEP2019  
 DESIGNED BY  
 ERM

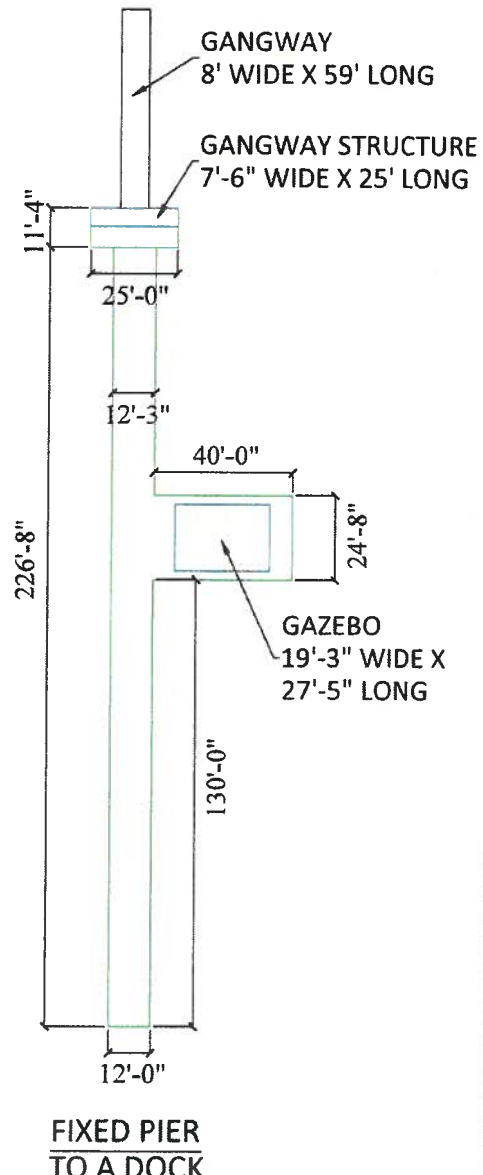
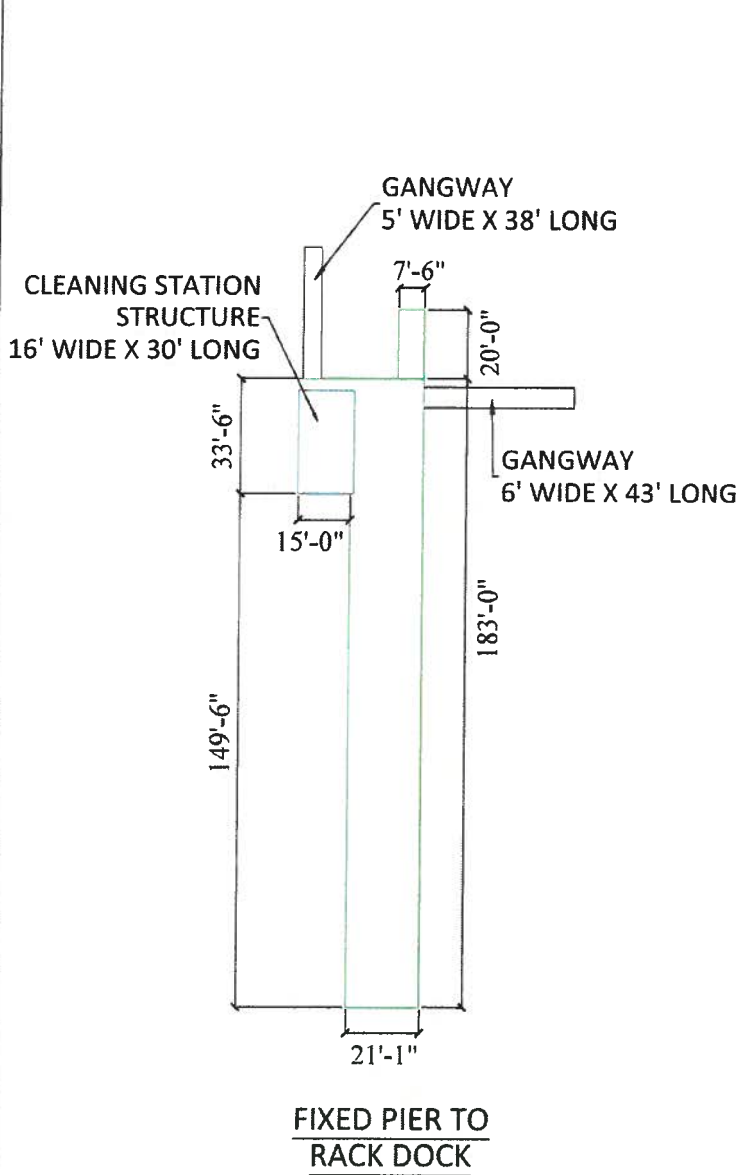

DESIGNED BY <b>ERM</b>	DATE 19SEP2019	DEALER <b>WAHOO COMMERCIAL</b>	VIEW FIXED PIERS	DOCK TYPE CAT 5	<small>THE INFORMATION CONTAINED IN THIS DRAWING IS THE SOLE PROPERTY OF WAHOO DOCKS. NO PART OF THIS DRAWING OR ANY REPRODUCTION THEREOF MAY BE REPRODUCED, STORED IN A RETRIEVING SYSTEM, OR AS A WHOLE, WITHOUT THE WRITTEN PERMISSION OF WAHOO DOCKS. IT IS FORBIDDEN.</small>	<small>www.wahoodocks.com</small> 203 CHESTERBRA DRIVE DAHLONEGA, GA 30533 PH: (770) 532-8411 FX: (770) 532-2983
		JOB NAME <b>GOLDEN ISLE - EXISTING</b>				

